

# FEIDER



**DRYWALL AND PANEL LIFTER**

**FLP335**

**USER GUIDE**

**CAUTION : Read the instructions before using the machine !**

# Contents

Assembly .....	3
Operator Controls .....	6
Operating Procedure .....	8
Disassembly .....	10
Maintenance .....	11
Extension Accessory .....	11
Parts Diagram .....	13
Parts List .....	14
DECLARATION OF CONFORMITY .....	16
WARRANTY.....	17
PRODUCT FAILURE.....	18
WARRANTY EXCLUSIONS .....	19

## Introduction

The Drywall Lift allows one person to lift a drywall panel that is up to 122 x487CM in size, without assistance. The panel can be raised to a maximum height of 335CM for attachment to level ceilings- or (with the lift's cradle tilted) to sloped ceilings or side walls. For higher ceilings, an Extension Accessory is available that increases maximum lift to 470CM.

The Lift's cradle lowers to 86.4CM. off the floor for easy panel loading, and can support up to 68kgs.

These instructions explain how to assemble the Lift, operate it, disassemble it after use for easy transport and storage, and order replacement parts. We urge you to read the Important Precautions below, and the Operation sections, before trying to use the Lift.

## Important Precautions



### WARNING

To protect against serious injury, use common sense and observe the following precautions when operating the Drywall Lift.

- ALWAYS study these instructions before operating, and pay close attention to all warnings.
- ALWAYS inspect the unit carefully before each day's use, pay special attention to the condition of the cable. The lift with long life if the cable in good status(without broken mark, without loose off at both end of the cable).
- ALWAYS allow the Lift to reach working room temperature before use (moving a cold unit into a warm room can cause condensation, which could affect the operation of the winch brake).
- Always be sure the brake drum is clean and dry before operating.
- NEVER use the Lift if either crossarm support is not secured by its locking spring tab.
- ALWAYS keep the work area free of obstructions.
- ALWAYS wear a hard hat when operating this Lift.
- ALWAYS watch for overhead obstructions when lifting the drywall panel.
- NEVER use the Lift for any purpose other than lifting a drywall panel.
- NEVER lift more than one sheet of drywall at a time. Never lift more than 68kgs.
- Never use the lift under frozen outdoor or indoor environment, potentially explosive atmospheres, mines.
- Never use the lift under environment of wind pressure in and out.
- Never allow children, people with disabilities to use the lift.
- The user shall work in accordance with the instruction handbook.
- It is necessary that the operator can watch the lifting device and the load during all movements;
- It is not allowed to work under the raised load until it is secured by suitable means;
- The noise value does not exceed 70 dB(A)

# Assembly

## Components

The Drywall Lift is shipped as several components that must be assembled before use:

- Tripod base assembly.
- Frame assembly, which includes a winch assembly and standard (122-cm) telescoping lift sections
- Cradle assembly, without its detachable crossarms
- Two cradle crossarm assemblies

## Assembly Procedure

1. Set up the tripod base:
  - a. Set the base on the floor, resting on its casters.
  - b. Press down on the slide yoke ring. Hold the ring down while you swing the two forward legs out until the yoke ring snaps into the locking hole on the bottom of the slide tube. (See Figure 1)
  - c. To prevent the tripod base from rolling backward during assembly, lower the backstop as shown.
2. Set the frame assembly onto the two "V" angles on the tripod base, and lower the frame about 1 in. until it is secured by the angles.

Before continuing, be sure the frame is pushed all the way down and is held securely by the angles.

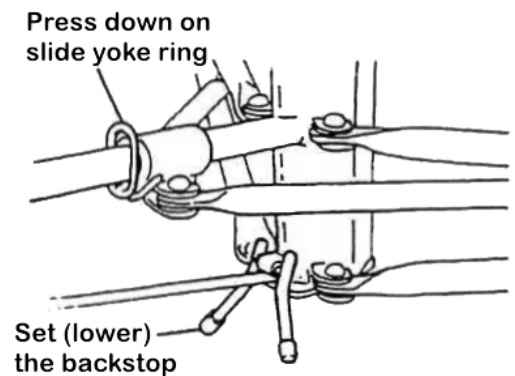
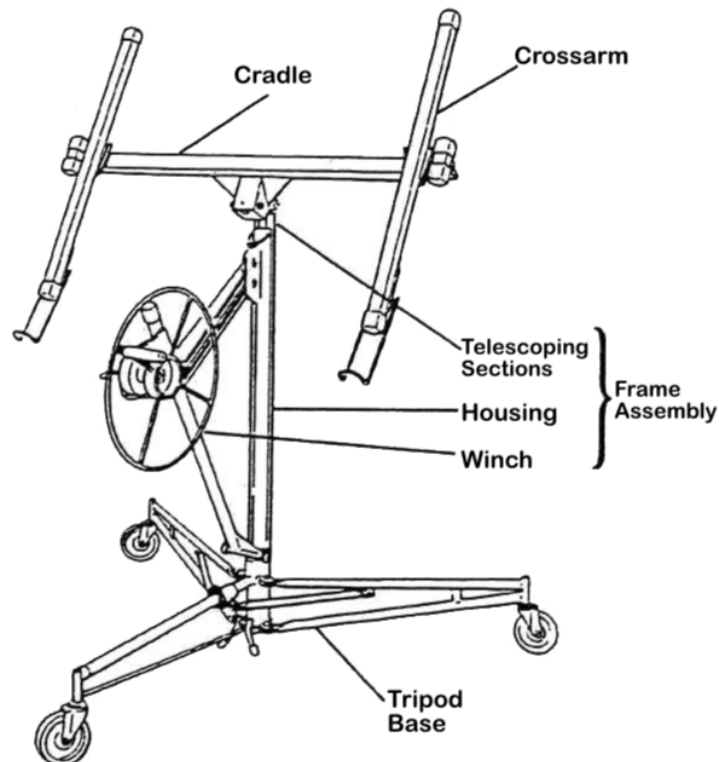

Figure 1



Components of Drywall Lift

## Assembly Procedure (continued)

3. Attach the handle to the winch wheel. Tighten the nut, then back it off slightly so the handle turns freely.
4. Move the winch assembly into its working position:
  - a. Hold the winch wheel and brake arm as shown in Figure 2. Rotate the winch wheel forward slightly while you lift on the brake arm to release the brake.
  - b. Raise the brake arm all the way up. Grasp the winch post, and grip the brake arm firmly with your thumb. (Figure 3)
  - c. Place your right hand on top of the frame. Continue to grip the brake arm as needed to prevent cable backlash, and pull the winch assembly all the way toward you. (Figure 4)
  - d. When the winch is fully extended (away from the frame housing), release the brake arm and swing the retaining hook away so it no longer secures the telescoping sections inside the frame housing.
5. Press the winch assembly slightly back toward the frame. This automatically engages the slide bar lock to keep the winch fully extended. (Figure 5)

**IMPORTANT:** Before continuing, be sure that the slide bar lock is fully engaged — that is, rotated clockwise as far as possible.

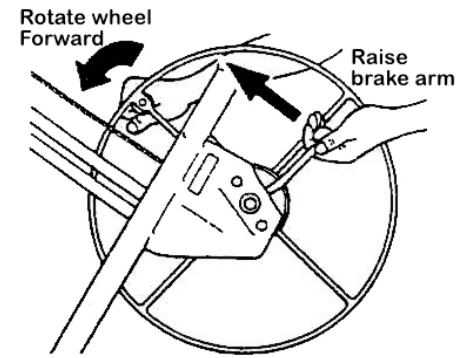

Figure 2

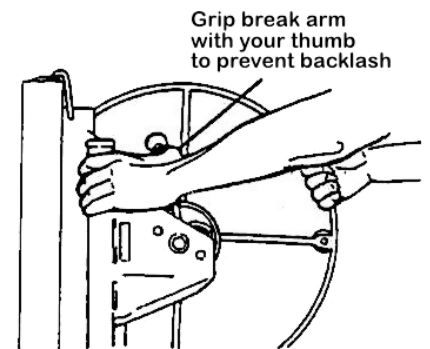

Figure 3

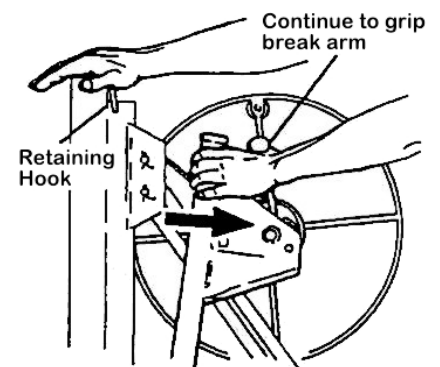

Figure 4

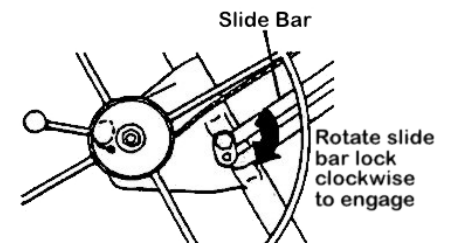

Figure 5

	<b>WARNING</b>
To avoid injury, slide bar lock must be fully engaged if winch assembly is extended.	

## Assembly Procedure (continued)

6. Attach the cradle to the frame (Figure 6):
  - a. Insert the cradle's post into the opening on top of the frame.
  - b. Secure the cradle to the frame by snapping the tilt latch upward so it hooks over the stud on the cradle.
7. Attach the crossarms to the cradle:

NOTE: The crossarms are interchangeable.

- a. Slide the tapered plates on the crossarms into the tapered sockets on the cradle. (Figure 7)
- b. Press each crossarm forward into the socket until the spring tab on the bottom of the crossarm snaps into place. (Figure 8)

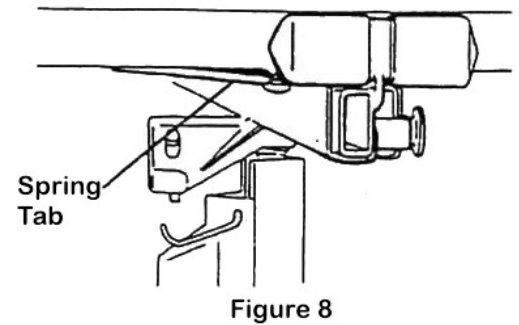
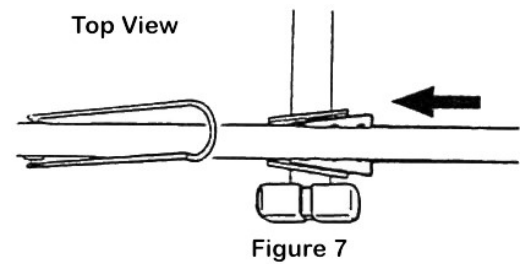
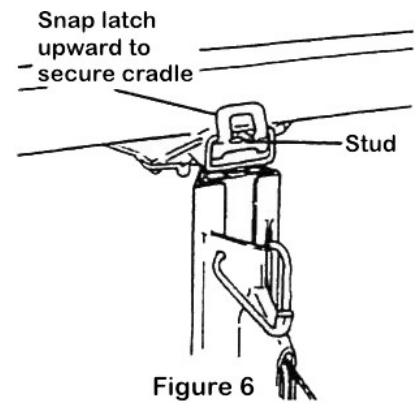

# Operator Controls

## Slide Yoke Ring

Press down on the slide yoke ring to unlatch the two forward legs so they can be rotated out to the Lift's working position or in to its storage position. A spring-loaded pin snaps into a hole on the bottom of the slide tube, to lock the folding legs position.

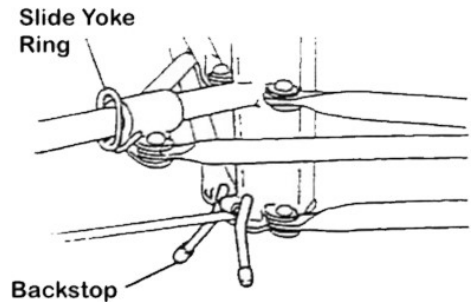

## Backstop

Pivot the backstop down to prevent the base from rolling backward, or up to allow the unit to wheel freely.

## Outriggers

The outriggers on the crossarms extend for supporting a longer drywall panel.

To extend an outrigger, pull out the lock pin with your right hand until you can slide the outrigger out with your left hand. The lock pin can engage to lock the outrigger at one of three positions: fully retracted; extended 21 in.; or extended 33 in.

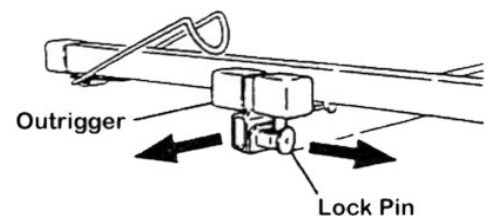

**IMPORTANT:** Never load a drywall panel or operate the Lift if the lock pins are not engaged at one of these three positions, or if the outriggers are extended beyond the 33-in. position.

To avoid damaging them, always fully retract the outriggers before transporting or storing the Lift.

## Panel Support Hooks

Open the support hook on each crossarm to support the drywall panel when it is being loaded, or when the cradle is tilted.

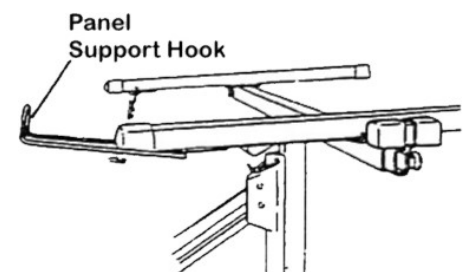

To avoid damaging them, always close the support hooks before transporting or storing the Lift.

## Slide Bar Lock

The slide bar lock holds the winch assembly at its operating (fully extended) position.

To fold the winch assembly against the frame (when disassembling the unit for transport or storage), disengage the lock by turning it counterclockwise as you lift on the slide bar.

When you reassemble the unit for operation, extending the winch assembly all the way and then pressing it back slightly toward the frame automatically engages the lock.

Never tighten the nut on the slide bar lock, or you will be unable to fold up the unit for transport and storage.

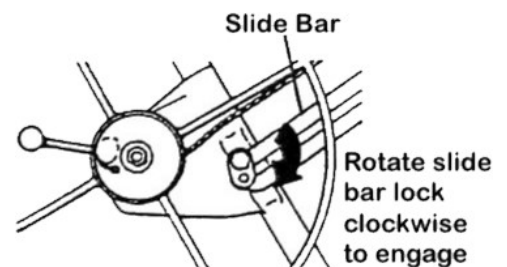

## Operator Controls (continued)

### Tilt Latch

To allow the cradle to tilt (for loading a dry wall panel, or for raising the panel to a side wall or sloped ceiling); or to remove the cradle from the frame, pivot the tilt latch out and down. To lock the cradle onto the frame without tilting, pivot the latch up to engage the stud on the cradle.

NOTE: When it is in the level (non-tilted) position, the cradle will also tilt up to 10° side-to-side.

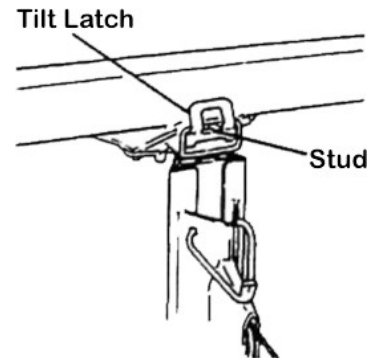

### Brake Arm

A spring-loaded brake holds the cradle at whatever height you raise it by cranking the winch wheel. To lower the cradle, control the backward rotation of the winch by grasping the wheel handle as you carefully raise the brake arm to release the brake.

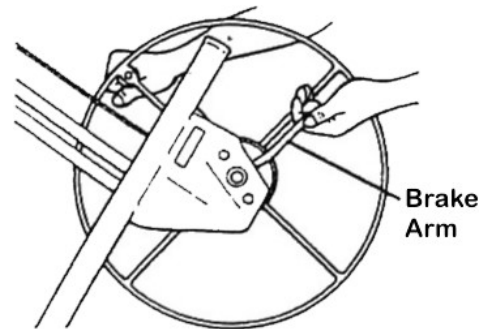

### Winch Wheel, Handle, and Post

Cranking the winch (using the wheel handle) coils or uncoils the cable that raises or lowers the cradle.

Grasp the post for leverage when cranking the winch.

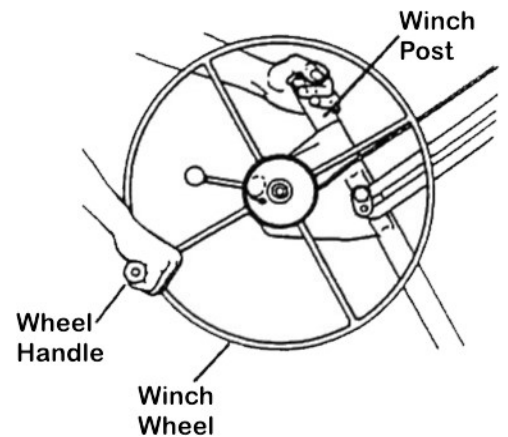

### Retaining Hook

The retaining hook secures the telescoping sections inside the frame, for transport and storage.

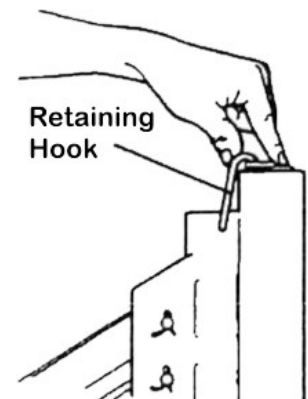

# Operating Procedure

**IMPORTANT:** Read the "Important Precautions" on page 3 before you operate the Lift.

## Safety Check Before Operation

Before you begin operating the Lift each day:

- Inspect the unit carefully for wear or damage. Pay special attention to the cable.
- Be sure the Lift is at working room temperature before operating.
- Be sure the winch brake drum is clean and dry before operating.

## To Load a Drywall Panel

1. Set (lower) the backstop, so the Lift won't roll backward (see page 7).
2. Swing open the panel support hooks on the two crossarms. Be sure the cradle is turned so the support hooks are on the opposite side from the winch wheel.
3. Extend the crossarm outriggers on the cradle as needed to fully support the length of the drywall panel (see page 7).
4. Release the tilt latch to tilt the cradle (see page 8).
5. Hold the drywall panel with its face paper toward the tilted cradle, and load the panel onto the Lift as shown. Set the panel onto the support hooks, and carefully lean it against the crossarms.
6. If installing the panel on a flat ceiling, tilt the cradle back up to its level position and lock the tilt latch. If installing the panel on a side wall or a sloped ceiling, leave the cradle tilted.
7. Raise the backstop on the base, and carefully roll the Lift close to the position where the panel will be installed.

 **WARNING**

To avoid serious injury, follow all "Important Precautions," page 3.

 **WARNING**

ALWAYS wear a hard hat when operating.

 **WARNING**

To avoid injury:

- Use ONLY for lifting a drywall panel.
- Lift ONLY one panel at a time.
- NEVER lift more than 68kgs.

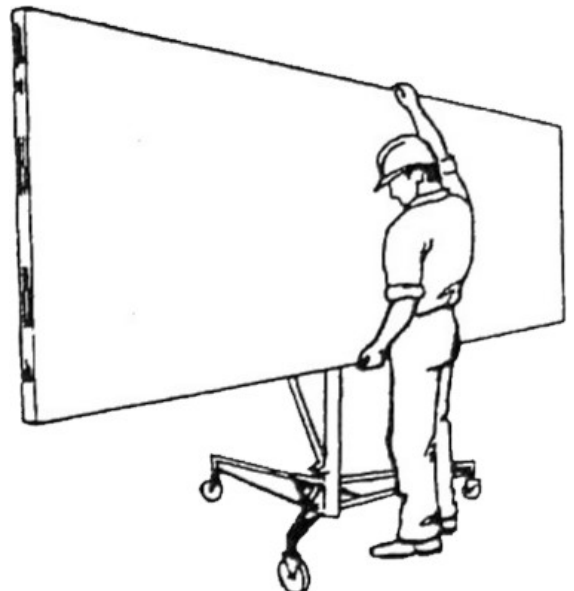

Figure 10



# Operating Procedure

## To Raise the Panel

**IMPORTANT:** Always lower the backstop before raising the panel to a sloped ceiling or a side wall.

Crank the winch wheel in the direction shown (hold the post for leverage) until the panel is at the desired height.

The brake is spring-loaded to automatically hold the cradle at the selected height when you stop cranking.

## To Lower the Panel

1. Grasp the wheel handle with your right hand so you can restrain the backward rotation of the winch.
2. Retain your hold on the winch handle. Carefully release the brake with your left hand and slowly rotate the wheel backward to lower the cradle to the desired height.

## Disassembly and Storage

Always store the On/wall Lift in a dry, protected area. To disassemble for more compact storage, refer to page 11.

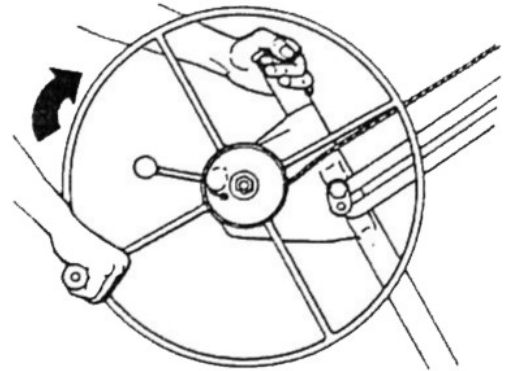

Figure 11

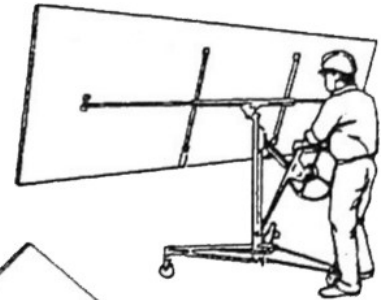

Figure 12

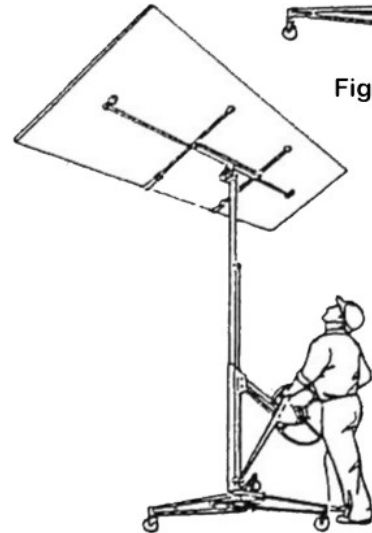

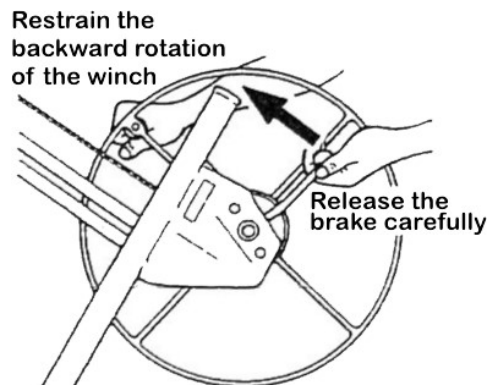

Figure 13

	<b>WARNING</b>
To avoid serious injury, watch for overhead obstructions when raising panel.	

	<b>CAUTION</b>
Cradle drops rapidly when brake arm is released.	
Control winch with your right hand on wheel handle BEFORE releasing brake.	



To Lower the Panel  
Figure 14

# Disassembly

To disassemble the Drywall Lift for transport or compact storage;

1. Crank the cradle all the way down.
2. Slide the cradle outriggers all the way in until they latch. Close the panel support hooks.
3. Remove the crossarms by pressing the spring tab on the bottom and sliding the crossarm out of the tapered socket.
4. Unlock the cradle tilt latch. Lift the cradle (about 7.5cm.) until you can remove it from the frame.
5. Rotate the winch wheel one full rotation forward as shown. This will raise the inner telescoping section.
6. Unlock the winch assembly by lifting the slide bar with your left hand while you rotate the slide bar lock counterclockwise with your right hand.
7. Hold the slide bar lock in this disengaged position (step 6) and press down on the telescoping sections in the frame with your left hand. The winch assembly will move toward the frame housing.
8. Crank the telescoping sections all the way down. Swing up the retaining hook as shown, and crank the telescoping sections back up slightly until secured by the hook.
9. Hold the retaining hook in this position with your left hand, and rotate the winch forward with your right hand.  
The winch assembly will fold up against the frame. When the slide bar contacts the frame, tighten the cable by turning the wheel further (just enough to hold the winch assembly in this position).
10. Carefully lift the frame/winch about 2.54cm. to free it from the tripod base.
11. To fold the base, press down on the slide yoke ring and pivot the forward legs in until they lock in the closed position.

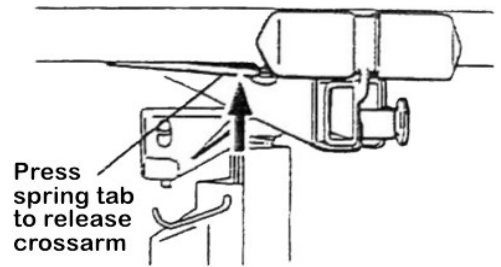

Figure 15

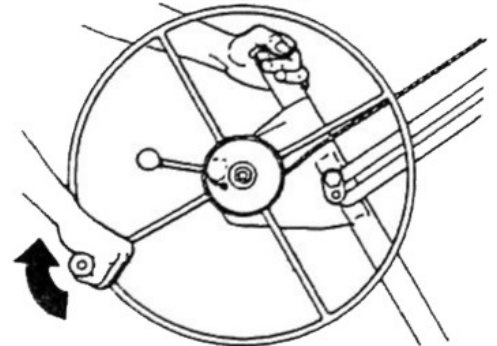

Figure 16

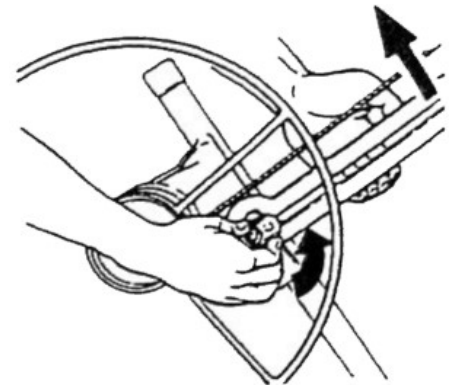

Figure 17

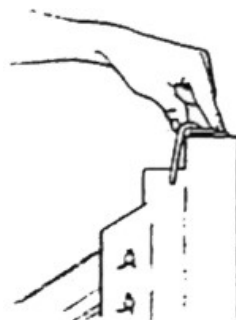

Figure 18

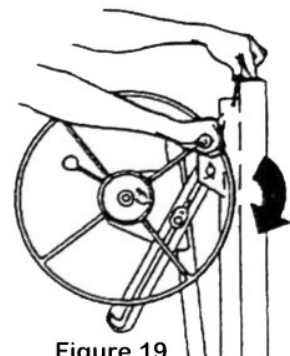

Figure 19

# Maintenance

- Inspect the cable before each work day. Replace it at the first sign of wear (refer to the instructions supplied with the replacement cable).
  - Occasionally oil the cable pulleys. Crank up the telescoping sections for access to the internal cable pulley. Never allow oil or grease to contact the surface of the winch brake drum.
  - Occasionally oil the caster bearings.
  - If the telescoping sections of the frame don't operate smoothly, apply household paraffin to the sliding surfaces.
- Need to check the state of the markings and that the markings remain as the initial one;
  - Jacks shall be maintained and repaired in accordance with the manufacturers instructions. Such maintenance and repair shall be carried out by qualified persons;
  - No modifications shall be carried out which adversely affect the compliance of the jack with this standard.

## Extension Accessory (sold separately)

For higher ceilings, an Extension Accessory is available that increases maximum lift to 470cm (instead of the standard 3350mm).

The Accessory consists of two 182cm telescoping sections that replace the standard 122cm sections in the frame. A longer cable is preinstalled in the telescoping sections, and must be attached to the winch drum.

### To Install the Accessory

#### Remove the Standard Telescoping Sections

1. Release the cable tension until you can loosen the cable from the mooring tab in the winch. Pull the cable out through the hole in the winch drum. (Figure 20)
2. With large pliers, grasp the top end of the two telescoping sections and lift them out of the frame housing as a unit. Pulling the free end of the cable toward the winch wheel will help raise the telescoping sections.

Remove the telescoping sections (and the cable) completely out of the frame housing.

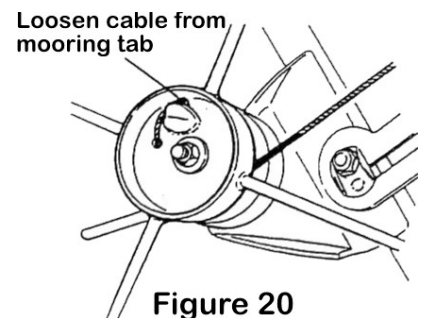

Figure 20

# Extension Accessory (Continued)

## Install the Longer Telescoping Sections

1. Feed the free (crimped) end of the Accessory's cable down into the pocket near the top the frame housing.  
**IMPORTANT:** The cable must be routed over the top of the pulley.
2. Pull the cable through the pocket, and slide the new telescoping sections down into [he frame.
3. Feed the free end of the cable under and around the winch hub, then through the hole into the winch drum.
4. Secure the crimped end of the cable firmly behind the mooring tab inside the drum.
5. Rotate the winch wheel forward to take up the slack in the cable.

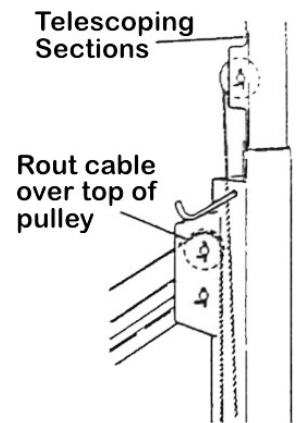



Figure 21

	<b>WARNING</b>
To avoid serious injury, cable must pass over She top of the pulley in the frame pocket.	

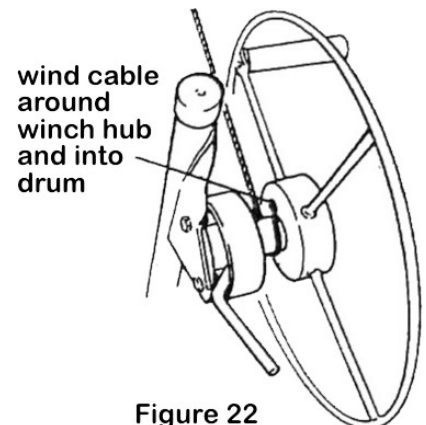

Figure 22

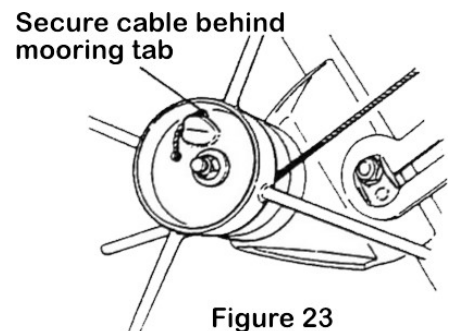
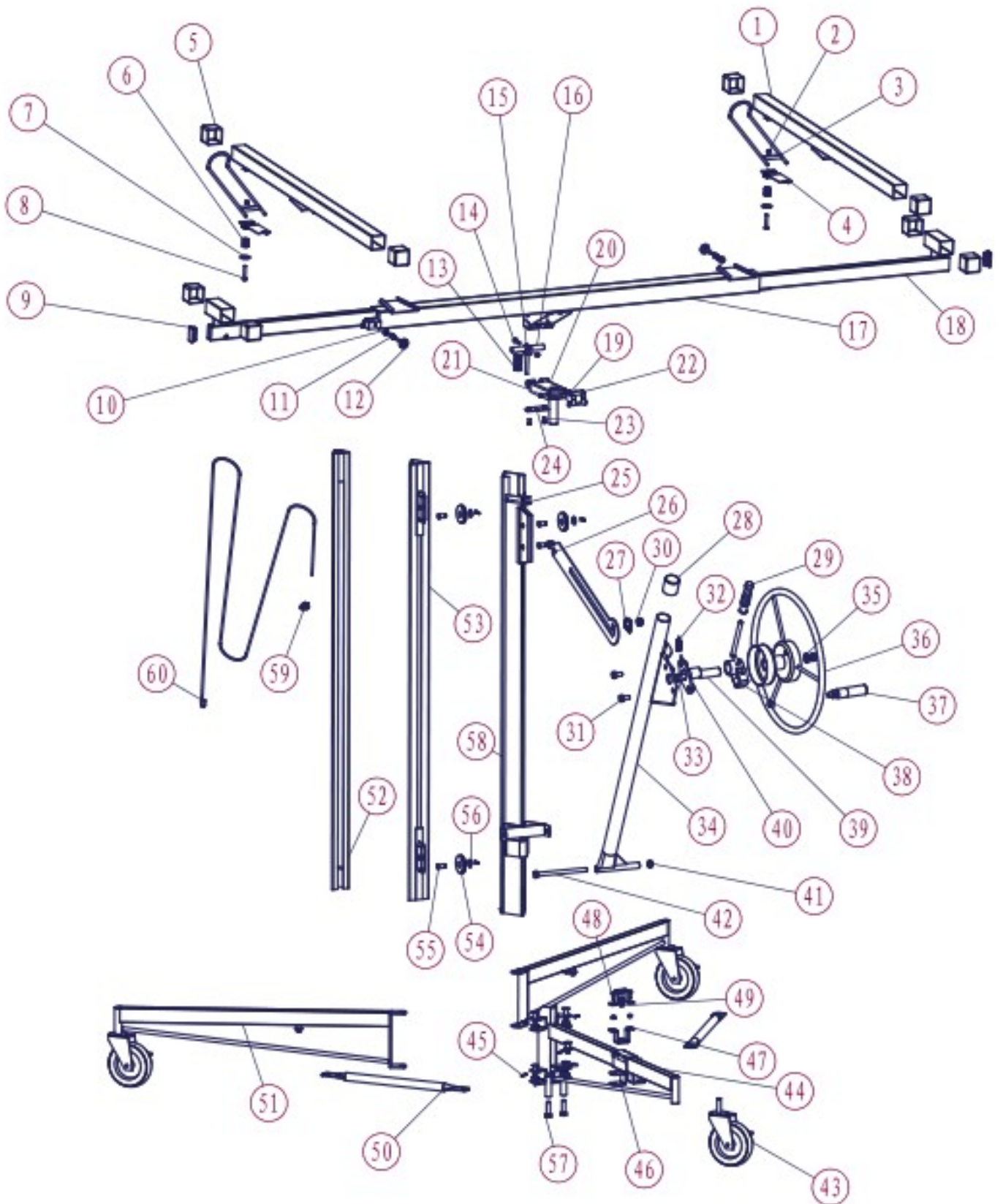

Figure 23

# Parts Diagram



# Parts List

Serial NO.	Description	Specification	Quality
1	supporting rod of the main bracket		2
2	hex-nut	M6 x 1	3
3	supporting rod		2
4	spring press plate		2
5	tube cap 2		8
6	spring press plate		2
7	flat washer	6N	2
8	hex-bolt	M6 x 35	2
9	tube cap 2		2
10	washer	6N	2
11	reset spring		2
12	T-pin		2
13	adjusting spring		1
14	hex-bolt	M6x25	1
15	spring rod		1
16	spindle		1
17	cross-bar		1
18	assistant bracket		2
19	hex self-locking nut	M6	6
20	steering gear base		1
21	hex-bolt	M6x60	1
22	safe lock		1
23	hex-bolt	M6x10	2
24	press plate		1
25	ox-horn		1
26	diagonal draw bar		1
27	unadjustable bolt		1
28	rubber sleeve		1
29	brake handle		1
30	hex-nut	M12	2
31	hex-bolt	M10x20	2
32	pull spring		1
33	hex-bolt	M12x120	1
34	side plate		1
35	flat washer	12N	1
36	round handle		1
37	rubber round handle		1
38	brake rubber handle		1
39	positioner		1
40	exciter shaft fixed plate		1
41	hex-nut	M10	1
42	hex-bolt	M10x150	1
43	wheel with brake	5"	3
44	main supporting bracket		1
45	split pin	2.5 x 18	12
46	sliding lock		1
47	spring plate		2
48	hex-bolt	M6x14	2
49	reset spring		1

50	supporting braket		2
51	assistant bracket		2
52	inner pillar		1
53	middle pillar		1
54	guide wheel		3
55	shaft pin		4
56	flat washer	10 N	12
57	hex-bolt	M10X35	2
58	outer pillar		1
59	wire rope lock		1
60	wire rope	4mm	1

# DECLARATION OF CONFORMITY



**BUILDER SAS**

**32, rue Aristide Bergès - ZI 31270 Cugnaux - France**, declares that,

Product: DRYWALL AND PANEL LIFTER

Model: FLP335

Serial number: 20250100001 -20250101230

Is in conformity with the essential requirements and other relevant provisions of the applicable European Directives, based on the application of European harmonized standards. Any unauthorized modification of the apparatus voids this declaration.

European Directives

Directive Machine 2006/42/EC

European harmonized standards

EN 1494:2000+A1:2008

EN ISO 12100: 2010

Cugnaux, 01/01/2025

A handwritten signature in black ink, appearing to be 'Philippe MARIE'.

Philippe MARIE / PDG

Responsible of the technical file: M. Olivier Patriarca



# WARRANTY

The manufacturer guarantees the product against defects in material and workmanship for a period of 5 years from the date of the original purchase. It can be extended by one year if the user subscribes to website of myswap. The warranty only applies if the product is for household use. The warranty does not cover breakdowns due to normal wear and tear.

The manufacturer agrees to replace parts identified as defective by the designated distributor. The manufacturer does not accept responsibility for the replacement of the machine, in whole or in part, and/or ensuing damage.

## **The warranty does not cover breakdowns due to:**

- insufficient maintenance.
- abnormal assembly, adjustment or operations of the product.
- parts subject to normal wear and tear.

## **The warranty does not extend to:**

- shipping and packaging costs.
- using the tool for a purpose other than that for which it was designed.
- the use and maintenance of the machine done in a manner not described in the user manual.

Due to our policy of continuous product improvement, we reserve the right to alter or change specifications without notice. Consequently, the product may be different from the information contained therein, but a modification will be undertaken without notice if it is recognized as an improvement of the preceding characteristic.

## **READ THE MANUAL CAREFULLY BEFORE USING THE MACHINE.**

When ordering spare parts, please indicate the part number or code, you can find this in the spare parts list in this manual. Keep the purchase receipt; without it, the warranty is invalid. To help you with your product, we invite you to contact us by phone or via our website:

**+33 (0)9.70.75.30.30**

**<https://services.swap-europe.com/contact>**

You must create a "ticket" via the web platform.

- Register or create your account.
- Indicate the reference of the tool.
- Choose the subject of your request.
- Describe your problem.

Attach these files: invoice or sales receipt, photo of the identification plate (serial number), photo of the part you need (for example: pins on the transformer plug which are broken).



**swap**

# PRODUCT FAILURE

## WHAT TO DO IF MY MACHINE BREAKS DOWN?

### If you bought your product in a store:

- Make sure that your machine is complete with all accessories supplied, and clean! If this is not the case, the repairer will refuse the machine.
- Go to the store with the complete machine and with the receipt or invoice.

### If you bought your product on a website:

- Make sure that your machine is complete with all accessories supplied, and clean! If this is not the case, the repairer will refuse the machine.
- Create a SWAP-Europe service ticket on the site: <https://services.swap-europe.com> When making the request on SWAP-Europe, you must attach the invoice and the photo of the nameplate (serial number).

Contact the repair station to make sure it is available before dropping off the machine.

Go to the repair station with the complete machine packed, accompanied by the purchase invoice and the station support sheet downloadable after the service request is completed on the SWAP-Europe site

**Please keep your original packaging to allow for after-sales service returns or pack your machine with a similar cardboard box of the same dimensions.**

For any question concerning our after-sales service you can make a request on our website <https://services.swap-europe.com>

Our hotline remains available at +33 (9) 70 75 30 30.



# WARRANTY EXCLUSIONS

## THE WARRANTY DOES NOT COVER:

- Start-up and setting up of the product.
- Damage resulting from normal wear and tear of the product.
- Damage resulting from improper use of the product.
- Damage resulting from assembly or start-up not in accordance with the user manual.
- Periodic and standard maintenance events.
- Actions of modification and dismantling that directly void the warranty.
- Products whose original authentication marking (brand, serial number) has been degraded, altered or withdrawn.
- Replacement of consumables.
- The use of non-original parts.
- Breakage of parts following impacts or projections.
- Accessories breakdowns.
- Defects and their consequences linked to any external cause.
- Loss of components and loss due to insufficient screwing.
- Cutting components and any damage related to the loosening of parts.
- Overload or overheating.
- Poor power supply quality: faulty voltage, voltage error, etc.
- Damages resulting from the deprivation of enjoyment of the product during the time necessary for repairs and more generally the costs related to the immobilization of the product.
- The costs of a second opinion established by a third party following an estimate by a SWAP-Europe repair station
- The use of a product which would show a defect or a breakage which was not the subject of an immediate report and/or repair with the services of SWAP-Europe.
- Deterioration linked to transport and storage\*.

\* In accordance with transport legislation, damage related to transport must be declared to carriers within 48 hours maximum after observation by registered letter with acknowledgement of receipt. This document is a supplement to your notice, a non-exhaustive list.

**Attention:** all orders must be checked in the presence of the delivery person. In case of refusal by the delivery person, it you must simply refuse the delivery and notify your refusal.

**Reminder:** the reserves do not exclude the notification by registered letter with acknowledgement within 72 hours.

### **Information:**

Thermal devices must be wintered each season (service available on the SWAP-Europe site). Batteries must be charged before being stored.

# FEIDER



CE

BUILDER SAS  
32 rue Aristide Bergès - Z.I. du Casque - 31270 Cugnaux - France  
Made in PRC